

# DG-SERIES

25-50 HP \ DIRECT GEAR DRIVE \ INDUSTRIAL ELECTRIC COMPRESSORS



\*Shown with optional tank mount

25 DG \ 30 DG \ 40 DG \ 50 DG

# SPECIFICATIONS

Model		25 DG	30 DG	40 DG	50 DG
Capacity @ 125 PSI	cfm	105	120	150	205
Motor	hp (kW)	25 (19)	30 (22)	40 (30)	50 (37)
Motor Speed	RPM	1,750	1,750	1,750	1,750
Sump Capacity	gallons (liters)	6 (22)	6 (22)	6 (22)	6 (22)
Discharge NPT	inches	1"	1"	1 1/4"	2"
Length (A)	inches (mm)	64 (1,626)	64 (1,626)	65 (1,651)	65 (1,651)
Width (B)	inches (mm)	33 (838)	33 (838)	35 (889)	34 (864)
Height (C)	inches (mm)	37 (940)	37 (940)	37 (940)	43 (940)
Weight	pounds (kg)	950 (431)	990 (449)	1,220 (553)	1,320 (599)

Note: Rated capacity in ACFM is based on standard conditions @125 psig.  
Capacity will vary with ambient conditions;  
i.e. temperature and barometric pressure, and compressor output pressure.

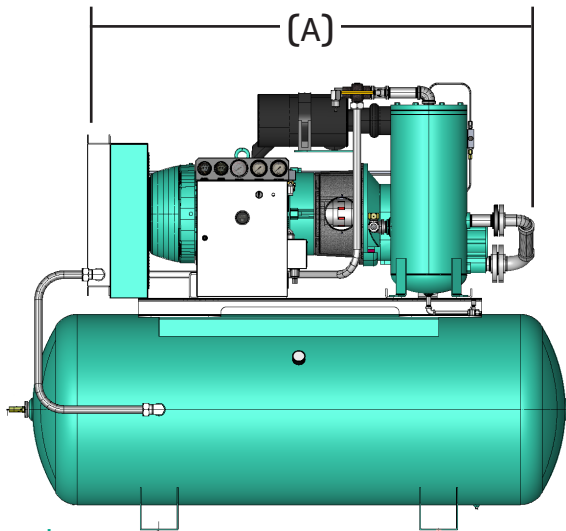

\*tanks size may vary

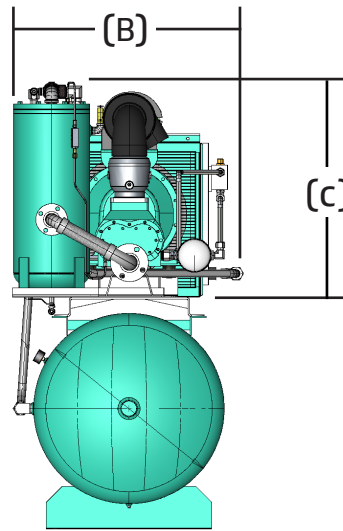

« Air Compressor shown with optional enclosure and microprocessor

## FEATURES

### COMPRESSOR UNIT:

- » Fluid flooded rotary screw, continuous duty, industrial air compressor.
- » Direct coupled to motor for positive alignment.

### ELECTRIC MOTOR:

- » Nema T-frame, C-face double shaft, open drip proof squirrel cage induction type.
- » 200/230/460/575/3/60 - 380/3/50

### MOTOR STARTER:

- » Full voltage magnetic starter with 115 controls, Nema 1 enclosure, circuit breaker, transformer and three-phase overload protector.
- » Nema 4, Wye Delta and VFD optional

### COUPLING & DRIVE:

- » Compressor is flange mounted to motor C-face for positive alignment and gear driven with low maintenance coupling.

### AIR INTAKE FILTER:

- » Corrosion resistant housing
- » Oversize multi-stage dry type with replaceable element.

### COOLING SYSTEM:

- » Air-cooled with air oil aftercooler and factory filled with Palasyn 45 synthetic lubricoolant.

### CONTROLS:

- » Auto dual control, full modulation, timed stop or constant run standard.
- » Analog controlled for smooth operation and lowest possible no load power.
- » Optional microprocessor.

### INSTRUMENTATION:

- » Line pressure gauge, fluid reservoir sightglass, hour meter, discharge temperature gauge, fluid filter and separator element differential gauges.

### PROTECTIVE DEVICES:

- » Class 20 overload relay, high temperature and overpressure shutdown.

### LUBRICATION:

- » Factory filled with Palasyn 45.
- » Equipped with microfiber full flow, spin on oil filter.

Sullivan-Palatek, Inc.

1201 West US Highway 20  
Michigan City, IN 46360

219.874.2497

sullivan-palatek.com

info@palatek.com